

All Weather Outdoor Kiosk Stand NEMA4 High Brightness LCD

SP3200
optional with PC/Antenna

32" LCD

SuntronicLCD's All-Weather/outdoor Full Sun environment Sunlight Readable LCD monitors allow you to view the display under the full sunlight. These affordable solutions are ready to deploy to any indoor and outdoor digital signage application for retail stores, restaurants, gas stations and many more...

We produce the largest and brightest Sunlight Readable LCD Monitor in sizes from 32" to 65"

FEATURES

- High Brightness & High Contrast LCD
- Auto Power on and Video signal on/off
- Safety AR/ Solar Blocking Glass
- Front Removable Glass
- Slick & Slim Bezel
- Air conditioning & Heater
- Powder Coated Finish
- IP65/NEMA4X Vandal Resistant Enclosures
- Flexible Mounting Options
- Air Curtain
- Built-in Waterproof Speakers

SPECIFICATIONS

Active area size (W x H)	32" (697.7 x 392. mm)
Panel resolution (pixels)	1366 x 768 WXGA
Luminance of white (Brightness)	1100 nits (Typ)
Contrast ratio	1500:1
Response time (gtg)	8 ms (Typ)
Colour Range	16.7 Million colours (max)
Viewing angle	85/85/85/85
Video inputs	VGA; DVI; S-Video
Auto Brightness Control	Yes (Optional)
Front glass type	Strengthen 6mm AR glass
IP Class	IP65
Operating temperature range	-40 to + 95F (Direct Sunlight) /122F (Under Shaded Area)
Storage Temperature	0 to 50C
CCFL Life Time	60K hrs (min)
Input voltage	110V
Weight	150lbs
External dimensions (W x H x D)	34"W x 23.7H x 11.5" D mm Notes: to guarantee a proper functionality, 6" of clearance must be kept around the display Please contact SuntronicLCD for details for SL3200
Portrait version	1. <i>Integrated CAT5/Fiber Optics VGA/DVI Extenders</i>
Options	2. <i>Custom Embedded PCs and Wireless</i> 3. <i>Serial RS232 Input</i> 4. <i>Screen Sensor/Environmental Sensors</i> 5. <i>Auto Brightness Control Sensors</i>
Customization	Integrated with Third Party Media player,
Customization	Please contact SuntronicLCD for available options



High Quality Parts

Our company uses only the best, using only High Quality parts along with components in USA or imported from Korea, Taiwan and Germany, for quality that you can trust!



Customer Service

Our customer service reps are here to help you with your LCD sign. From general questions to technical support, we leave you feeling completely satisfied.



US Manufactured

Our LCD Signs are assembled, tested and shipped from our very own factory, giving us the ability to customize signs to your needs.

LPC7050WT (Optional)

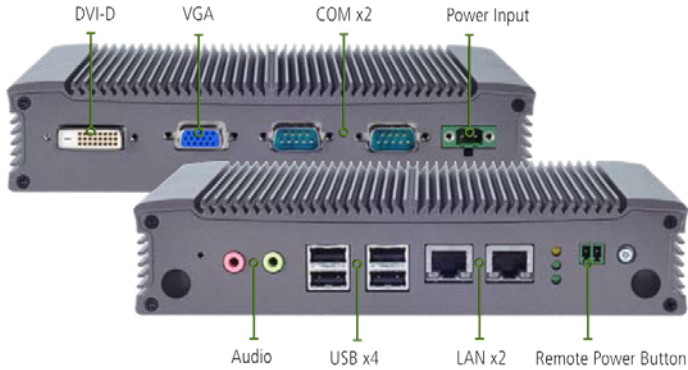

Cable-free interior

The interior of this product contains no wires, making this industrial product as rugged as possible.

Multiple display ports

This platform comes with multiple video-out ports to allow easy integration with any signage setup.

Integrated SIM card reader

Integrated in a mini-PCIe slot, the SIM card readers allow for users to enable 3G use for their IPC.

Intel® Atom™ N2800

Dual core Cedar Trail Intel Atom CPUs feature the 1.8 GHz N2800 which uses 6.5 Watts.

Fanless

This IPCs lifespan has been extended by removing the most easily damaged component, the fan.

Extreme operating temperature

This product is ruggedized to support a wider than usual range of temperatures. Outfitted with industrial components (HDD/SSD, CF, Memory) this appliance can thrive in harsh conditions.

Dust proof design

Solid chassis design with a fanless interior allows for this product to be completely dustproof when installed correctly, insuring longevity of the product.

Screw-locked power plug

This power plug is made to screw directly into the appliance chassis, allowing secure power connection in even the harshest of settings.

LED indicators

LED indicators makes it easy to check working status.

LPC7050WT SPECS:

Dimensions (WxHxD)		198x42x145mm (7.80" x1.65" x5.71")
Processor		Intel Atom N2800
Chipset		Intel NM10
System Memory	Technology	DDR3 SODIMM x1
	Max. Capacity	Up to 4GB
Storage	IDF	CF socket Type I/II x1
	SATA	2.5" SSD/HDD drive bay x1
Ethernet Controller		Intel 82574 x1; Intel 82583V x1
Graphic Controller		Intel Integrated Graphics Media Accelerator 3650
Audio Controller		RTL ALC886 x1
I/O	LAN	GbE RJ45 x2
	Display	DB15 x1 for VGA (1920x1200) DVI-D x1 (1920x1200)
	Video Grabber	N/A
	Audio	Phone Jack x2 for Mic-in and Line-Out
	Serial I/O	DB9 x2 supports RS232/422/485
	GPS	N/A
	USB 2.0	Type A x4
	Power Input	2-pin terminal block
	Expansion	Mini-PCIe x2 (one with SIM card reader)
	Others	External: Power-On Button, SMA Antenna Hole Internal: Reset
Power Input		+24Vdc +/-5% ATX Mode
AC Adapter		60W +24V @ 2.5A
Hardware Monitor		Fintek F81865F Integrated Watchdog Timer 1-255 level
OS Support		Linux XPE, XP Pro FES, WS7E, WS7P, Win 7 Pro FES
Certifications		CE, FCC Class A
Compliance		N/A
Operating Temp. Range	w/ Industrial Components	-20~55°C / -4~131°F
	w/ Commercial Components	-5~45°C / 23~113°F



High Quality Parts

Our company uses only the best, using only High Quality parts along with components in USA or imported from Korea, Taiwan and Germany, for quality that you can trust!



Customer Service

Our customer service reps are here to help you with your LCD sign. From general questions to technical support, we leave you feeling completely satisfied.



US Manufactured

Our LCD Signs are assembled, tested and shipped from our very own factory, giving us the ability to customize signs to your needs.

OUTDOOR ANTENNA (TRAB24003P) - (Optional)

WHITE OR BLACK: Our UHF and 800/900 MHz Phantoms are now available in either white or black ABS plastic. ABS plastic is highly shock resistant. Both can be painted to the color of your application by using a nonmetallic paint.

WHIPLESS DESIGN: The revolutionary patent pending whipless design of our Phantom™ antenna allows car washes without removing the antenna. Whipless means they don't look like antennas, attract less attention, less vandalism, and have lower wind resistance. Phantom. s™ are also less susceptible to be broken by trees and garages.

FIELD DIVERSITY: Field diversity means that the antenna is simultaneously sensitive to both the electric and magnetic fields of the signal, like having two antennas. Field diversity makes the antenna resistant to the picket-fence fading that is always found in urban operation.

MEAN-EFFECTIVE-GAIN: The radiation pattern of our Phantom™ antennas are specially tailored to aim the signals in the right direction for mobile operation by utilizing a low radiation angle and a broad beamwidth. When used in mobile operation, in urban or suburban areas, our phantom antennas have been proven to outperform any gain antenna.

PERMANENT MOUNTING: Permanent mount versions of the UHF and higher frequency models are available for those high risk applications such as metering where antennas must resist vandalism and achieve economical mounting.

TRAB24003P

800/900 MHz 3 dB-MEG BLACK MODELS

Frequency Range = 2400-2500 MHz

Radome height = 2.30"

Gain = 3 dB-MEG*



Technical Data - Product Features & Information

	VHF	220 MHz
Gain:	Unity	Unity
Frequency Range:	144-150 MHz 150-156 MHz 156-162 MHz	220-230 MHz
VSWR:	<1.5:1 850 kHz <2.0:1 1.5 MHz	<1.5:1 2.2 MHz <2.0:1 4.0 MHz
Maximum Power:	100 watts	100 watts
Bandwidth:	1.5 MHz	4 MHz
Impedance:	50 ohms	50 ohms
Height:	3½"	2½"

Horizontal Field Patterns

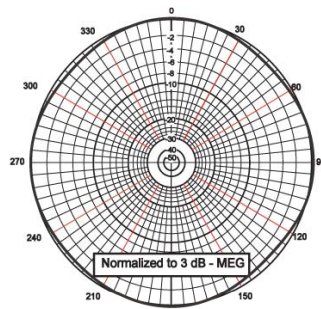

TRAB1500

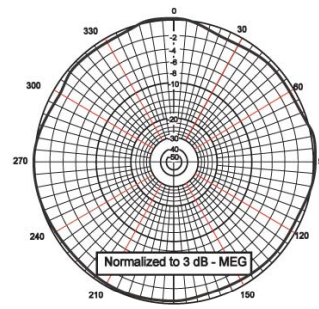

TRAB2200

VSWR

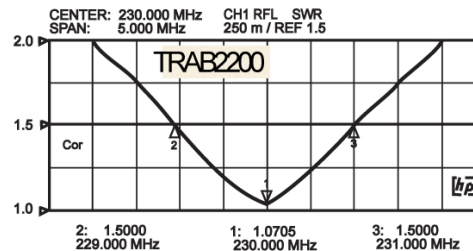
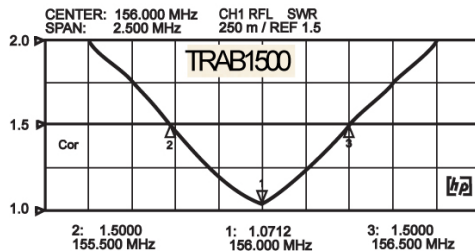

High Quality Parts

Our company uses only the best, using only High Quality parts along with components in USA or imported from Korea, Taiwan and Germany, for quality that you can trust!



Customer Service

Our customer service reps are here to help you with your LCD sign. From general questions to technical support, we leave you feeling completely satisfied.



US Manufactured

Our LCD Signs are assembled, tested and shipped from our very own factory, giving us the ability to customize signs to your needs.

MECHANICAL DRAWINGS

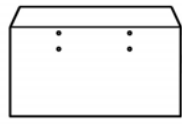

TOP

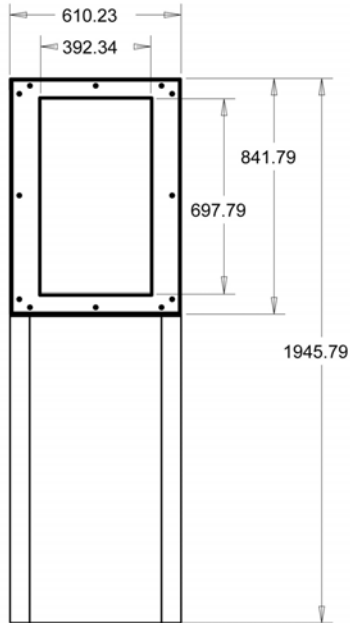

FRONT



SIDE

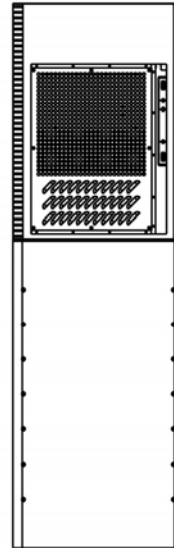

BACK

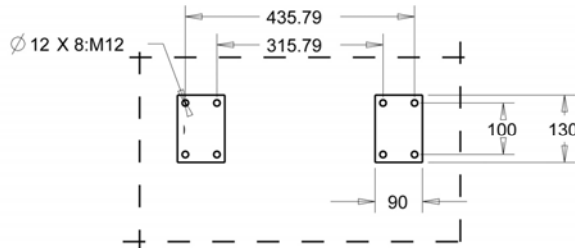
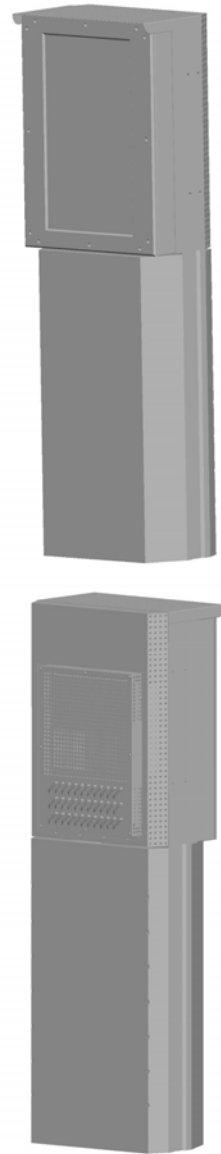

SCALE 0.150

BOTTOM

CONCRETE MOUNTING

-  NEMA4
IP65
-  TEMP
-40F~122F
-  HIGH
BRIGHTNESS
1500nits
-  HEATER
-  DIRECT
SUNLIGHT

